

# Resolution Measures in Single Particle Analysis

Houston, December 2002

**Pawel A. Penczek**

**The University of Texas – Houston Medical School,  
Department of Biochemistry and Molecular Biology,  
6431 Fannin, MSB6.218, Houston, TX 77030, USA.**

**phone: (713) 500-5416**

**fax: (713) 500-0652**

**[Pawel.A.Penczek@uth.tmc.edu](mailto:Pawel.A.Penczek@uth.tmc.edu)**



**THE UNIVERSITY *of* TEXAS**

**HEALTH SCIENCE CENTER AT HOUSTON**

**MEDICAL SCHOOL**

# Optical resolution

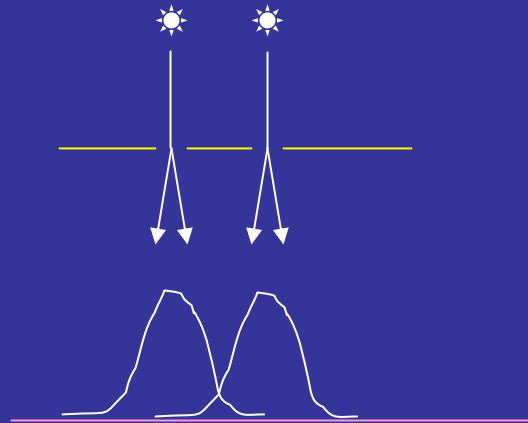

The resolution of a microscope objective is defined as the smallest distance between two points on a specimen that can still be distinguished as two separate entities.

Resolution is a somewhat subjective concept.

The theoretical limit of the resolution is set by the wavelength of the light source:

$$R = \text{const } \lambda$$

# Optical resolution

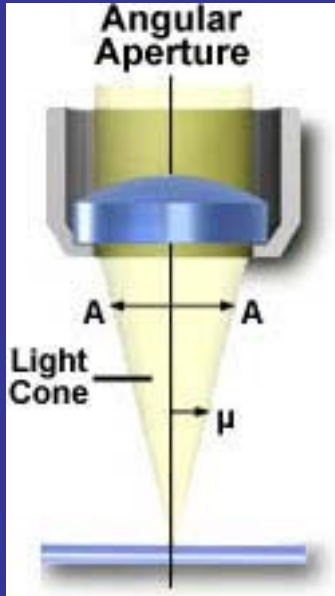

When light from the various points of a specimen passes through the objective and is reconstituted as an image, the various points of the specimen appear in the image as small patterns (not points) known as Airy patterns. The central maximum of the Airy patterns is often referred to as an Airy disk, which is defined as the region enclosed by the first minimum of the Airy pattern and contains 84 percent of the luminous energy.

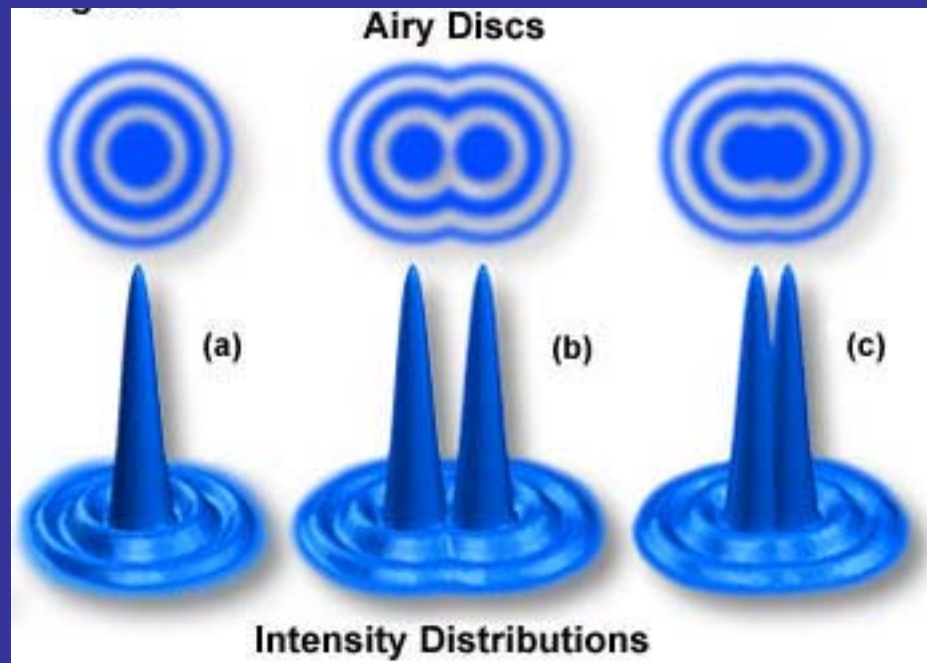

# Optical resolution

Hypothetical **Airy disk** (a) consists of a diffraction pattern containing a central maximum (typically termed a zeroth order maximum) surrounded by concentric 1st, 2nd, 3rd, etc., order maxima of sequentially decreasing brightness that make up the intensity distribution.

If the separation between the two disks exceeds their radii (b), they are resolvable.

The limit at which two Airy disks can be resolved into separate entities is often called the **Rayleigh criterion**.

When the center-to-center distance between the zero'th order maxima is less than the width of these maxima, the two disks are not individually resolvable by the Rayleigh criterion (c).

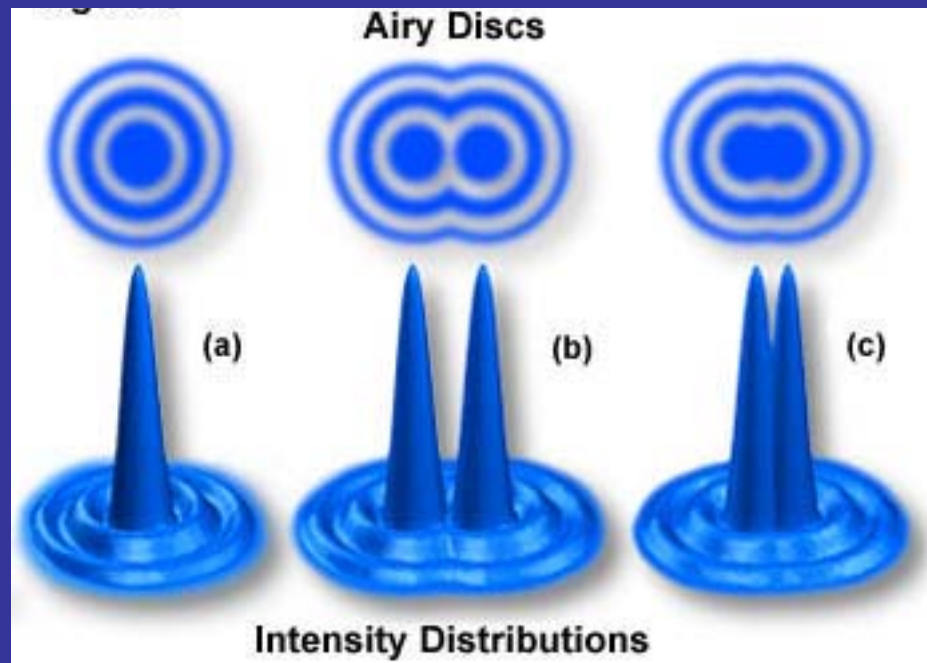

# Resolution-limiting factors in electron microscopy

- The wavelength of the electrons  
(depends on the voltage: 100kV - 0.037 Å; 300kV – 0.020Å)
- The quality of the electron optics  
(astigmatism, envelope functions)
- The underfocus setting.  
The resolution of the TEM is often defined as the first zero in the contrast transfer function (PCTF) at Scherzer (or optimum) defocus.
- Signal-to-Noise Ratio (SNR) level in the data
- Accuracy of the alignment

# The concept of optical resolution is not applicable to electron microscopy and single particle analysis

- In single particle analysis, there is no “external” standard by which the resolution of the results could be evaluated.
- Therefore, the resolution measures in EM have to estimate “internal consistency” of the results.
- Unless an external standard is provided, objective estimation of the resolution in EM is not possible.

# FRC - Fourier Ring Correlation

Saxton W.O. and W. Baumeister.

The correlation averaging of a regularly arranged bacterial cell envelope protein.

J. Microsc., **127**, 127-138 (1982).

FSC – Fourier Shell Correlation (3D)

# DPR – Differential Phase Residual

Frank J., A. Verschoor, M. Boublik.

Computer averaging of electron micrographs of 40S ribosomal subunits.

Science, **214**, 1353-1355 (1981).

2D & 3D

# SSNR – Spectral Signal-to-Noise Ratio

Unser M., L.B. Trus, A.C. Steven.

A new resolution criterion based on spectral signal-to-noise ratios.

Ultramicroscopy, **23**, 39-52 (1987).

Penczek, P. A.

Three-dimensional Spectral Signal-to-Noise Ratio for a class of reconstruction algorithms.

J. Struct. Biol., **138**, 34-46 (2002)

# Q-factor

van Heel M. and J. Hollenberg.

The stretching of distorted images of two-dimensional crystals.

In: Proceedings in Life Science: Electron Microscopy at Molecular Dimensions (Ed.: W. Baumeister).

Springer Verlag, Berlin (1980).

only 2D

# Fourier Ring Correlation

$$FSC(R) = \frac{\sum_{n \in R} F_n G_n^*}{\left\{ \left( \sum_{n \in R} |F_n|^2 \right) \left( \sum_{n \in R} |G_n|^2 \right) \right\}^{1/2}}$$

A. either:

1. Split (randomly) the data set of available images into halves;
2. Perform the alignment of each data set “independently”;

B. or:

1. Perform the alignment of the whole data set;
2. Split (randomly) the aligned data set into halves;
3. Calculate two averages (3D reconstructions);
4. Compare the averages in Fourier space by calculating the FRC.

**WARNINGS** - method B valid *only* if the noise component in the data is independent (not aligned)  
- the two sets in method A might not be as independent as one assumes.

# Fourier Shell Correlation FSC

First set of images  $F$

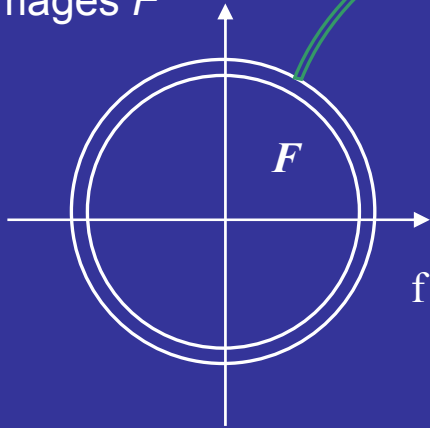

Second set of images  $G$

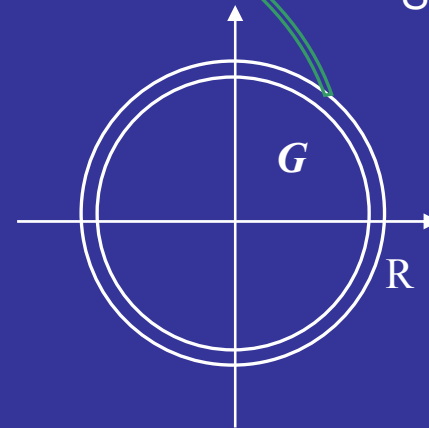

$$FSC(R) = \frac{\sum_{n \in R} F_n G_n^*}{\left\{ \left( \sum_{n \in R} |F_n|^2 \right) \left( \sum_{n \in R} |G_n|^2 \right) \right\}^{1/2}}$$

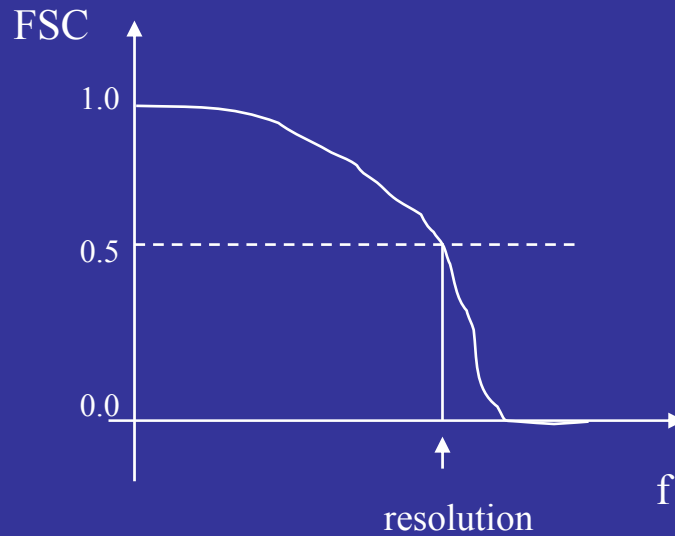

# Fourier Shell Correlation

## WHY DOES IT WORK?

FSC provides a measure of the Spectral Signal-to-Noise Ratio in the reconstruction.

## WHAT DOES IT HAVE TO DO WITH RESOLUTION?!?

FSC is directly related to the alignment error.

# Signal *versus* noise

When we perform multiple measurements of the same phenomena, we equate the “*signal*” with the part of the measurement that remains the same between measurements, and we assume that the varying part of measurements is the “*noise*”.

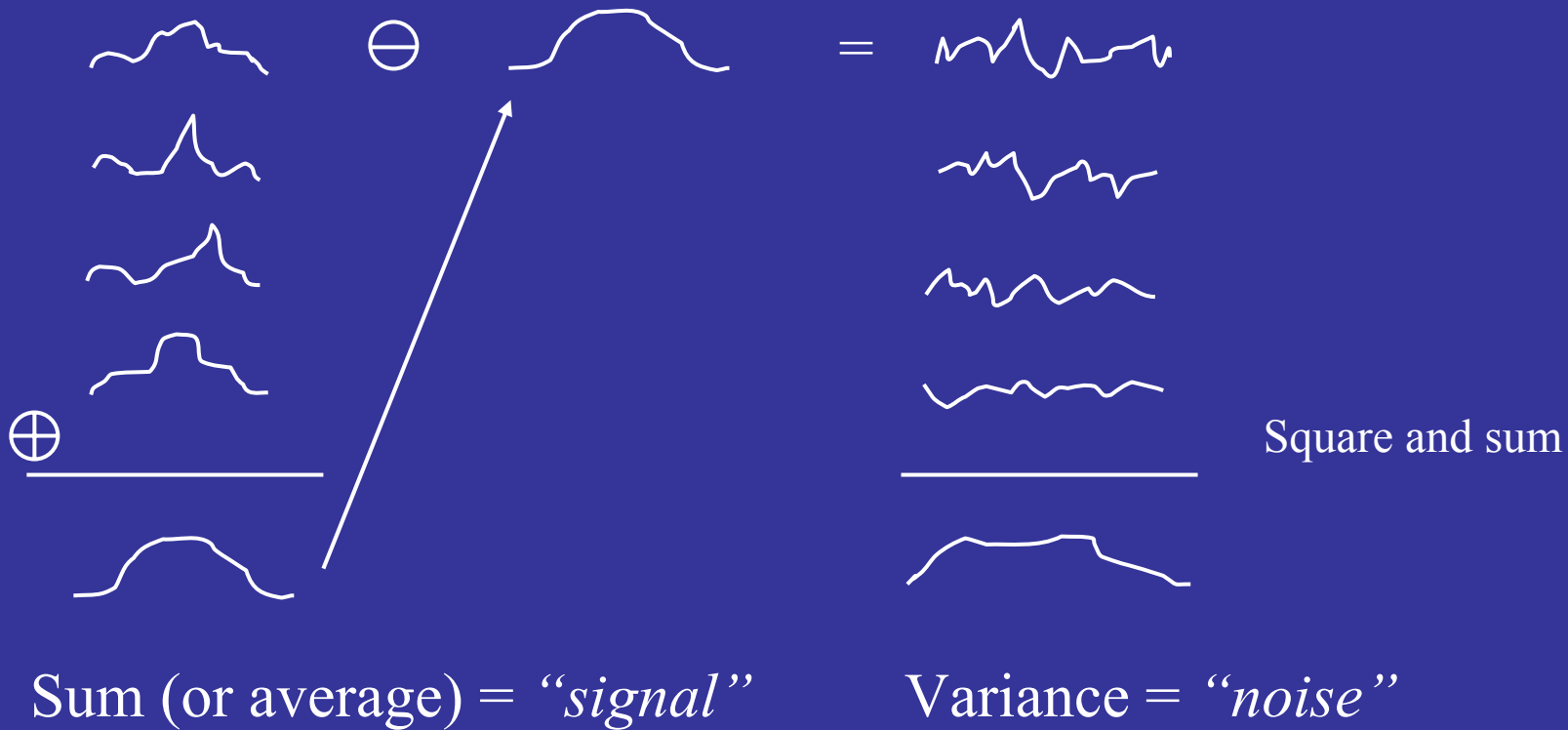

## Signal-to-Noise Ratio (SNR)

$$\text{SNR} = \frac{\text{Power of signal}}{\text{Power of noise}}$$

# Spectral Signal-to-Noise Ratio (SSNR) in 2D

A set of Fourier transforms of 2D images.

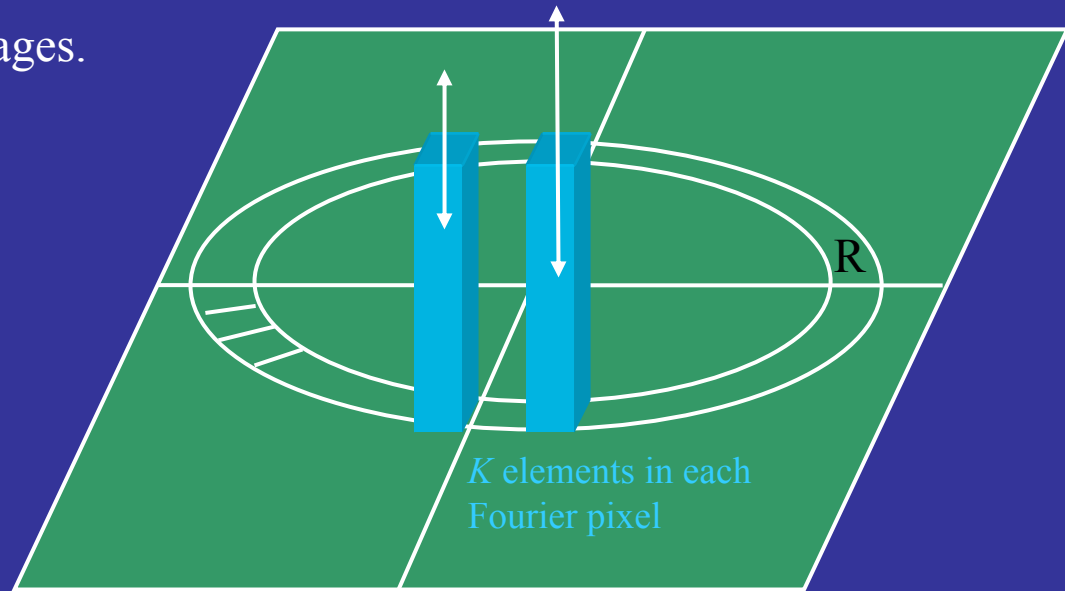
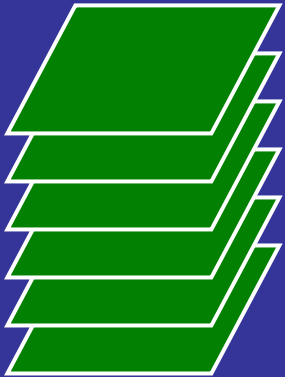

Calculate SSNR according to the equation:

$$SSNR(R) = \frac{\sum_{n \in R} \left| \sum_k F_{n,k} \right|^2}{\frac{K}{K-1} \sum_{n \in R} \sum_k \left| F_{n,k} - \langle F \rangle_n \right|^2} - 1$$

where  $\langle F \rangle_n = \frac{1}{K} \sum_k F_{n,k}$

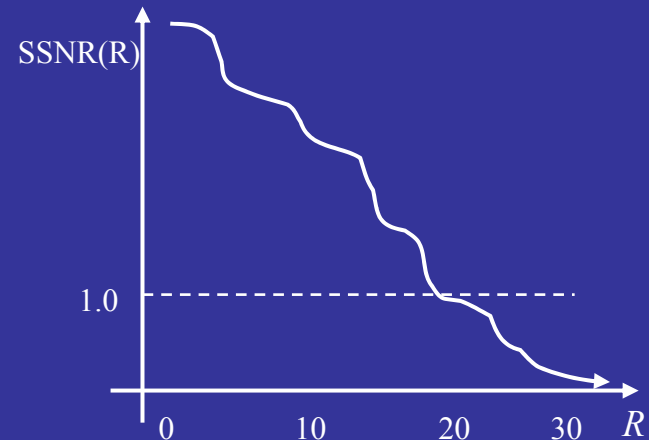

## Relations between FRC and SSNR

$$SSNR = \frac{FSC}{1 - FSC};$$

$$FSC = \frac{SSNR}{SSNR + 1}$$

For large number of images  $Variance(SSNR) \cong Variance(FSC)$

When FSC is calculated for a data set split into halves:

$$SSNR = 2 \frac{FSC}{1 - FSC}$$

FSC is a biased estimate of SSNR.

For large number of images, the bias is negligible.

The expectation value of FRC is calculated as

$$E[FRC] \cong \frac{E[\sum_{n=1}^{N_R} F^n G^{n*}]}{E\left[\left\{\left(\sum_{n=1}^{N_R} |F^n|^2\right)\left(\sum_{n=1}^{N_R} |G^n|^2\right)\right\}^{1/2}\right]}$$

$$= \frac{\sum_n F_T^{n^2}}{\sum_n F_T^{n^2} + \sum_n \frac{1}{L} \sigma_N^{n^2}} = \frac{\frac{\sum_n F_T^{n^2}}{\sum_n \frac{1}{L} \sigma_N^{n^2}}}{\frac{\sum_n F_T^{n^2}}{\sum_n \frac{1}{L} \sigma_N^{n^2}} + 1} = \frac{SSNR}{SSNR + 1}$$

# Test of 3D SSNR

$$\text{SSNR} = \text{FSC} / (1 - \text{FSC})$$

$$\text{FSC} = \text{SSNR} / (\text{SSNR} + 1)$$

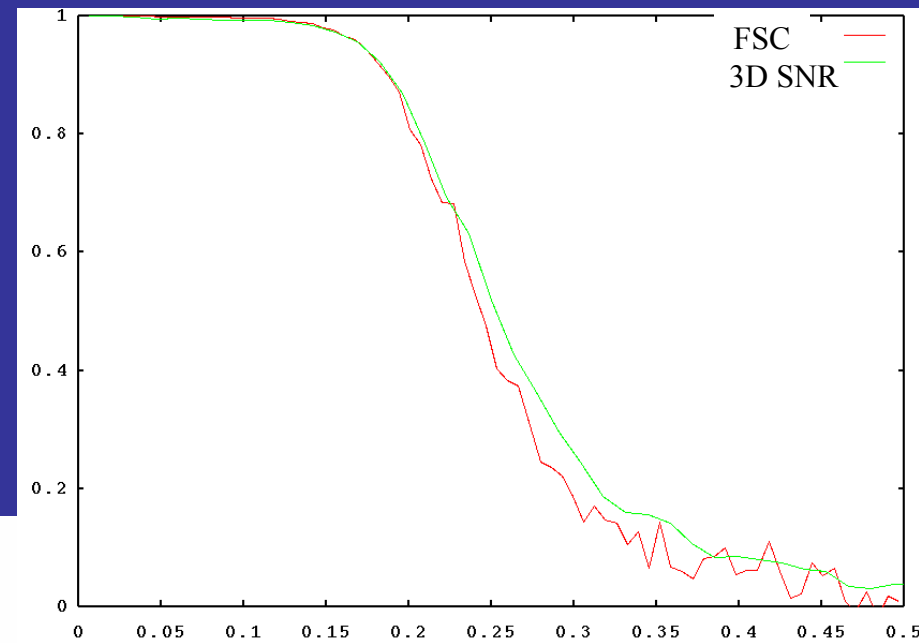
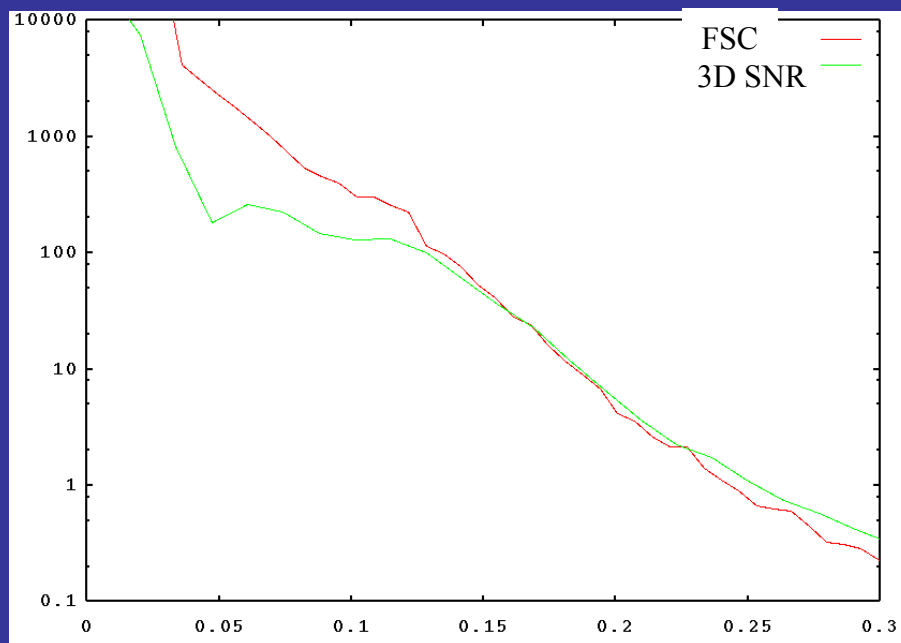

Journal of Structural Biology 138 (2002) 34–46

Structural  
Biology

www.academicpress.com

## Three-dimensional spectral signal-to-noise ratio for a class of reconstruction algorithms

Pawel A. Penczek\*

*Department of Biochemistry and Molecular Biology, The University of Texas Houston Medical School, 6431 Fannin, MSB6.218, Houston, TX 77030, USA*

Received 17 December 2001; and in revised form 13 May 2002

Resolution criteria  
should be based on the SNR considerations

$$SSNR = 2 \frac{FSC}{1 - FSC}$$

Reasonable criterion: include only Fourier information that is above the noise level, i.e.,  $SSNR > 1$ .

$$SSNR = 1 \Rightarrow FSC = 1/3 = 0.333$$

Another criterion: ( $3\sigma$ ) include Fourier information that is significantly higher than zero, i.e.,  $SSNR > 0$ .

$$SSNR = 0 \Rightarrow FSC = 0$$

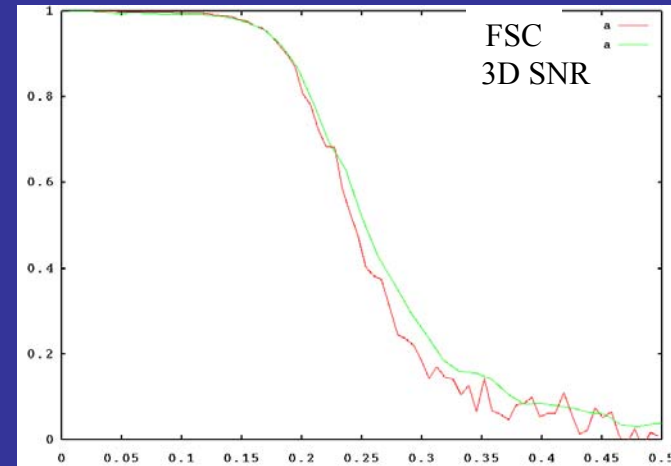

# FSC can be used to cross-validate EM results

---

(crossresolution)

EM structure



X-ray crystallographic structure

electron density map, the voxel values are  
proportional to the Coulomb potentials of atoms

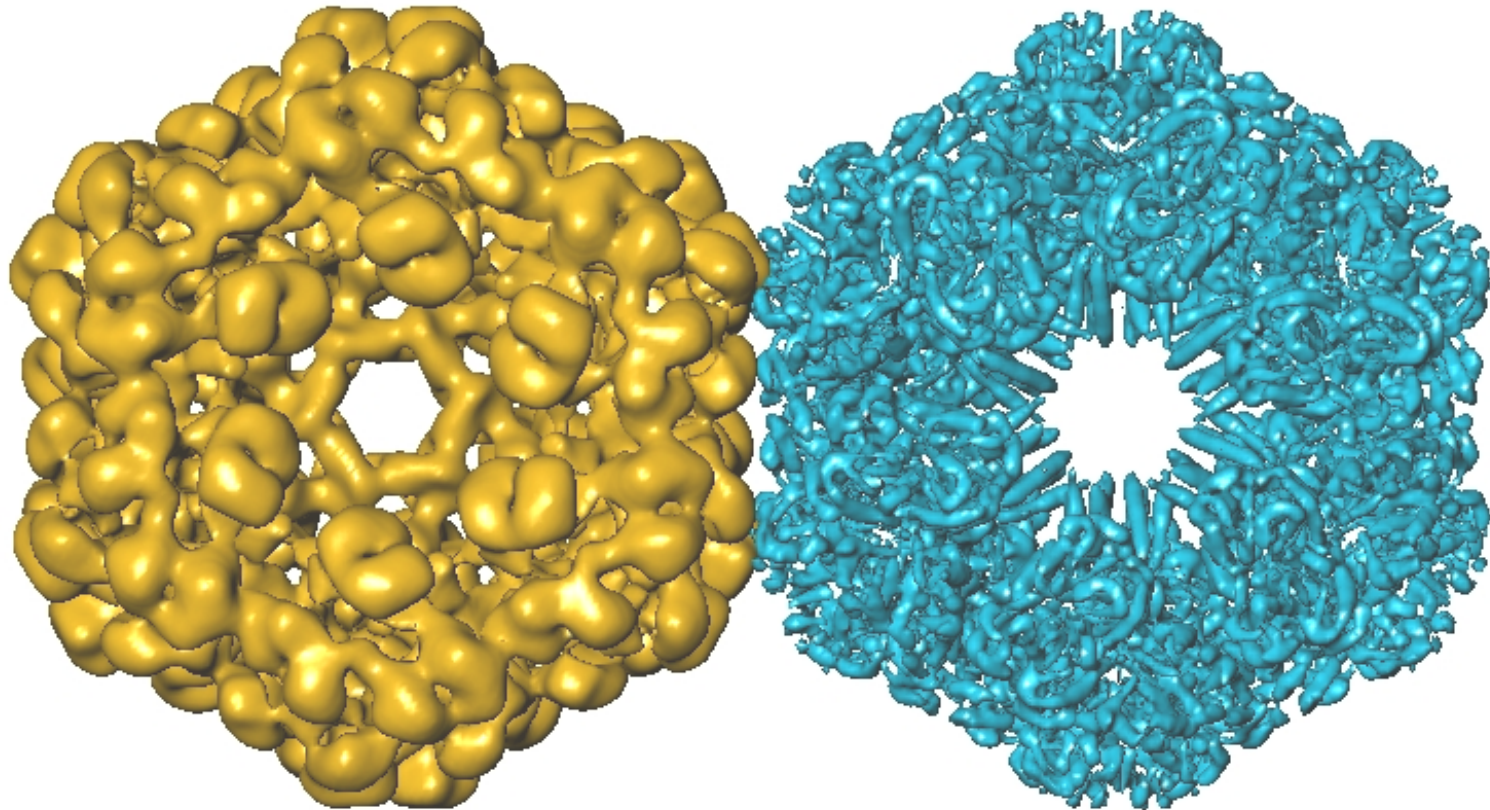

# Comparison of *Lumbricus terrestris* hemoglobin cryo-EM map at 14.9 Å with X-ray crystallographic map at 5.5 Å.

Top view

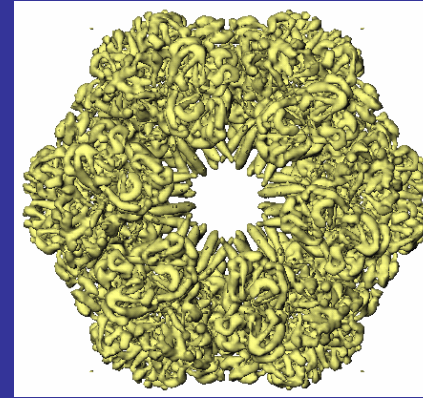
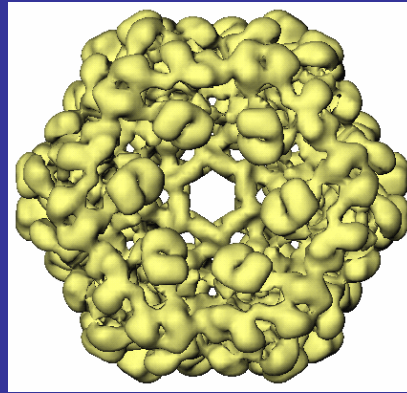

Hemoglobin dodecameric complex shown along local approximate 3-fold symmetry axis.

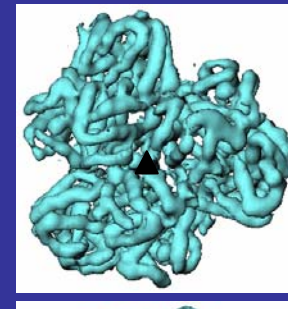
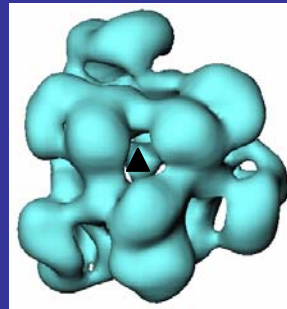

Side-view of the dodecameric hemoglobin complex. The approximate local 3-fold symmetry axis that relates the hemoglobin subunits and the globular portion of the portion of the linker complex is vertical.

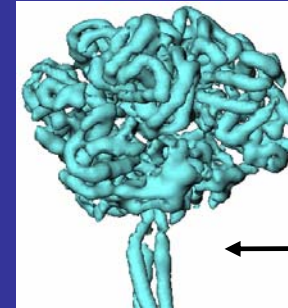
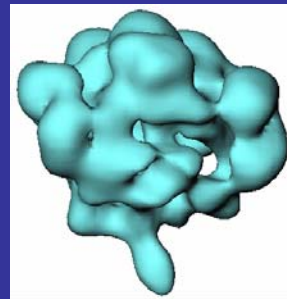

Long and short triple-stranded coiled-coils.

↑  
3-fold

↑  
3-fold

EM structure

X-ray crystallographic map  
filtered to the resolution of the EM map

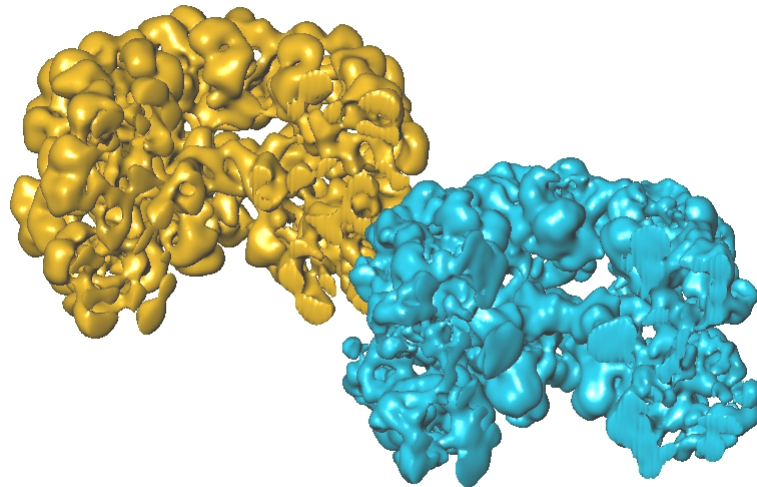
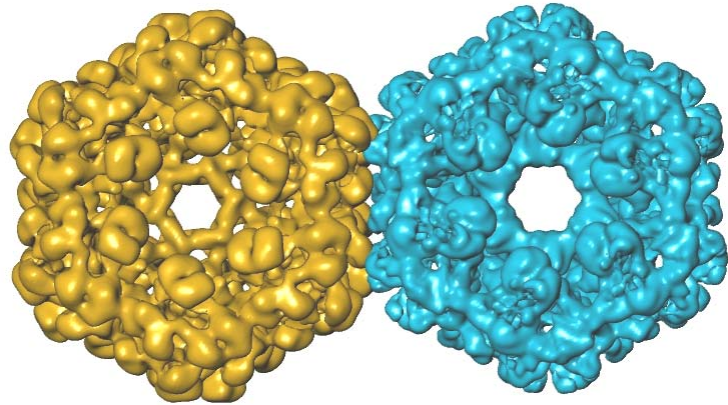

# Crossresolution

relation between FRC and SSNR

X-ray map  $F$   
(noise-free)

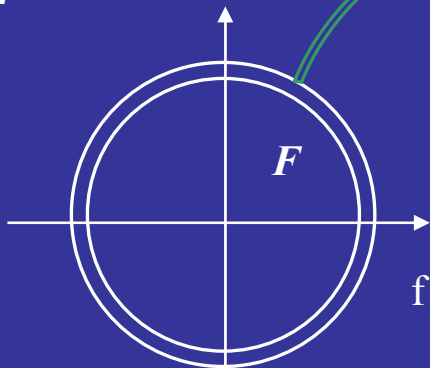

EM map  $G$   
(corrupted by noise and  
other errors)

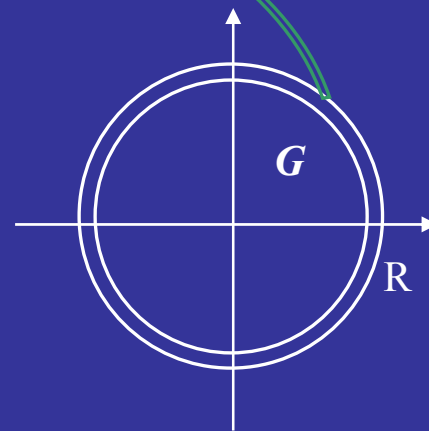

$$FSC(R) = \frac{\sum_{n \in R} F_n G_n^*}{\left\{ \left( \sum_{n \in R} |F_n|^2 \right) \left( \sum_{n \in R} |G_n|^2 \right) \right\}^{1/2}}$$

$$SSNR = \frac{FSC^2}{1 - FSC^2}$$

$$SSNR = 1 \quad \Rightarrow \quad FSC = \sqrt{\frac{1}{2}} = 0.71$$

Crossresolution

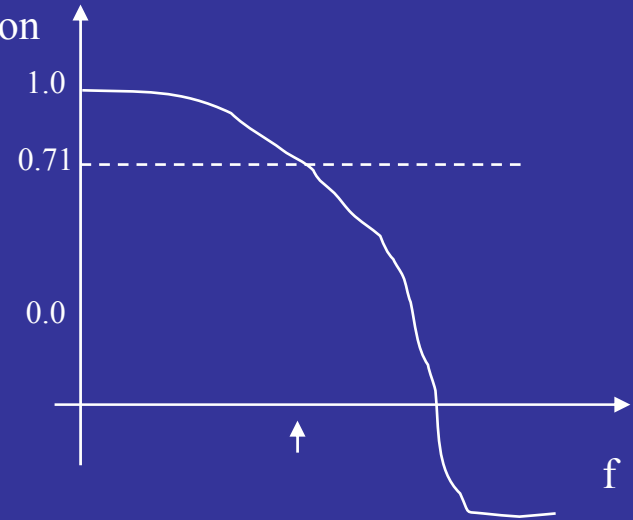

# Resolution *versus* crossresolution

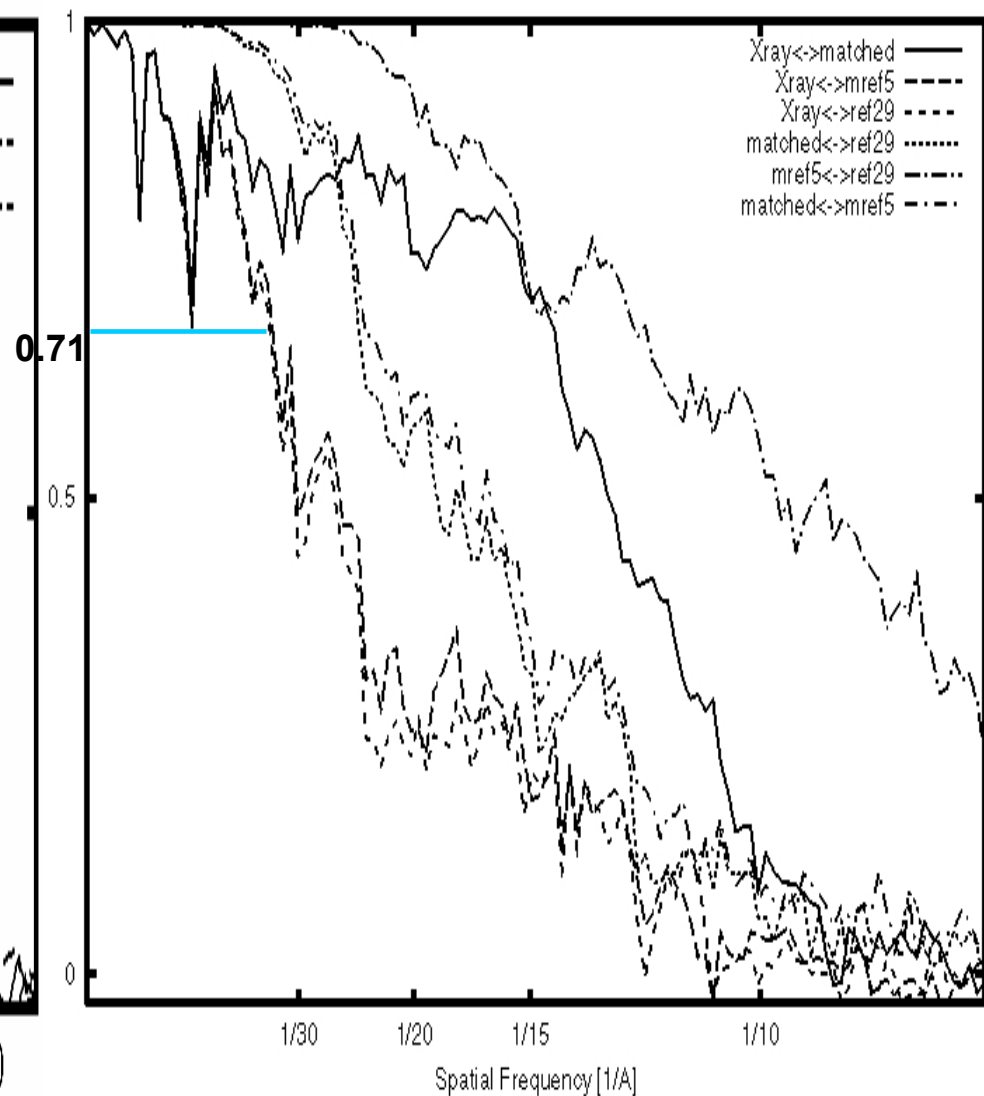
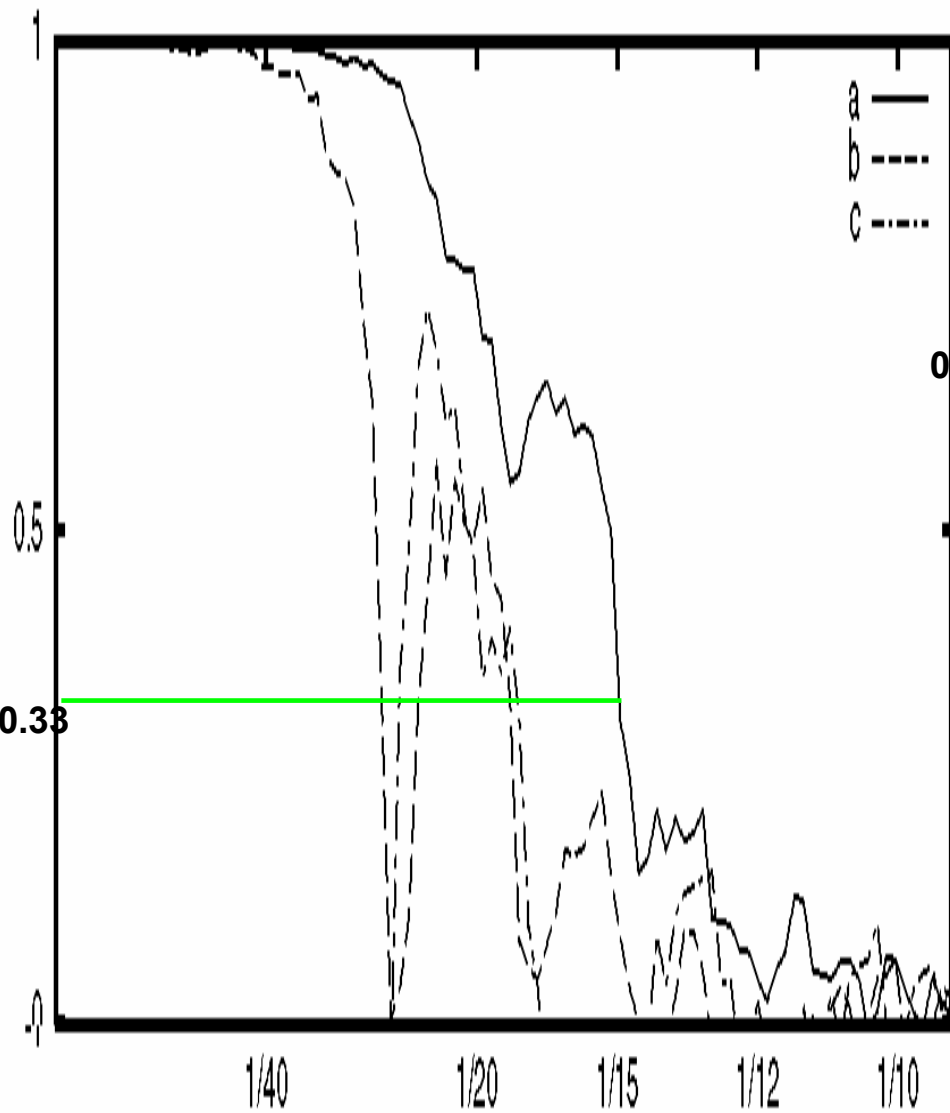

# Summary

- ❖ The concept of optical resolution is not applicable to electron microscopy and single particle analysis.
- ❖ The resolution measures in EM estimate the “internal consistency” of the results. The outcome is prone to errors. The existing resolution measures cannot distinguish between “true” signal and the aligned (correlated) noise component in the data.
- ❖ FSC and SSNR are mathematically largely equivalent, although the SSNR-based estimate of the spectral signal to noise ratio has lower statistical uncertainty than the FSC-based estimate.
- ❖ The SSNR should be used whenever the number of the input projections is too small to make the division into halves possible (tomography).
- ❖ A reasonable resolution criterion should be based on the SSNR in the data and set such that the Fourier coefficients with a dominant noise component are excluded from the final analysis. For example,  $SSNR=1 \Rightarrow FSC=0.333$ .